

(No Model.)

3 Sheets—Sheet 1.

H. GRUSON.
GUN CARRIAGE.

No. 367,617.

Patented Aug. 2, 1887.

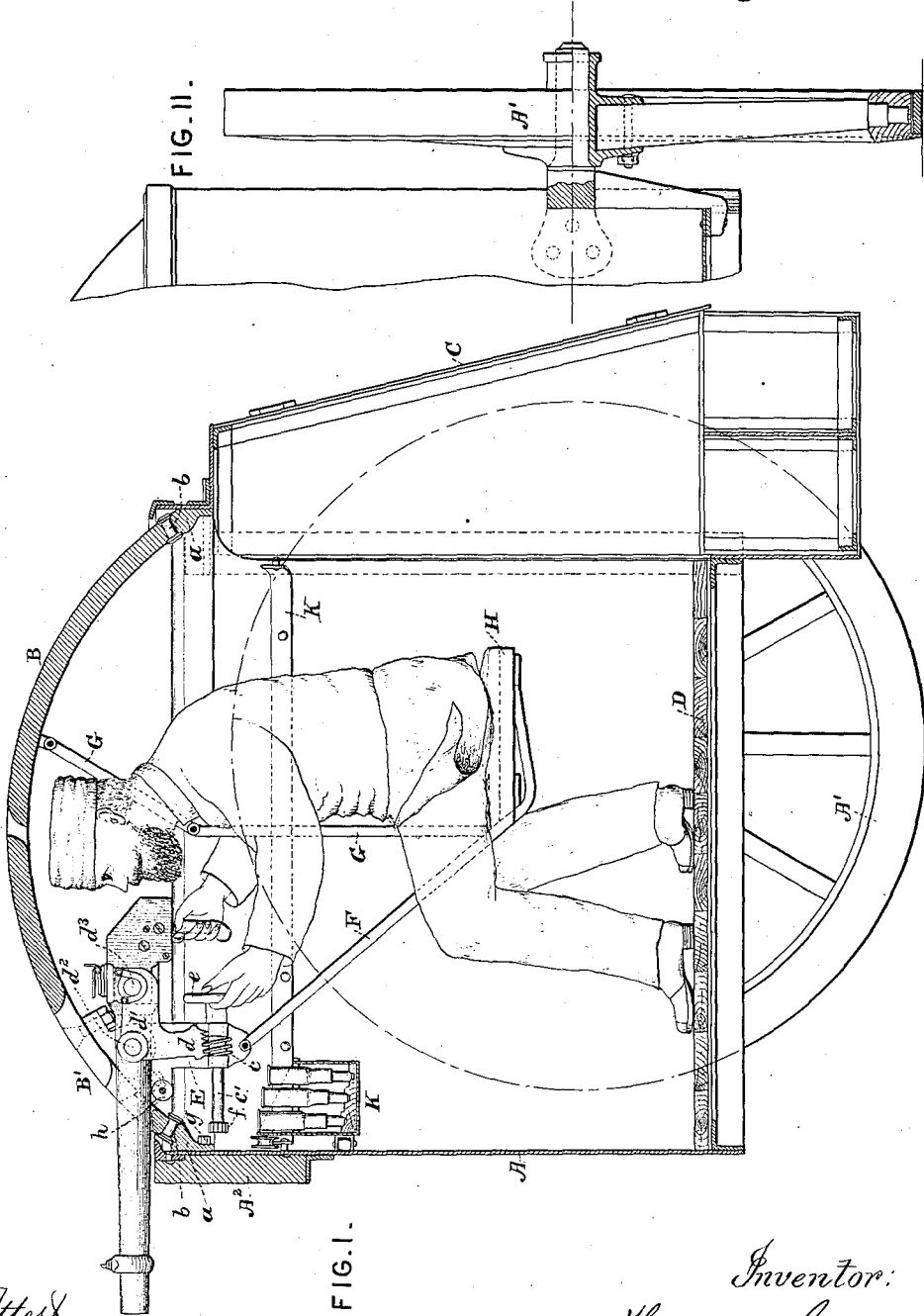

Attest.
 Geo. T. Smallwood.
 F. A. No. 111111

Inventor:
 Hermann Gruson.
 By *Knights Bros*
 attys

(No Model.)

3 Sheets—Sheet 2.

H. GRUSON.
GUN CARRIAGE.

No. 367,617.

Patented Aug. 2, 1887.

FIG. III.

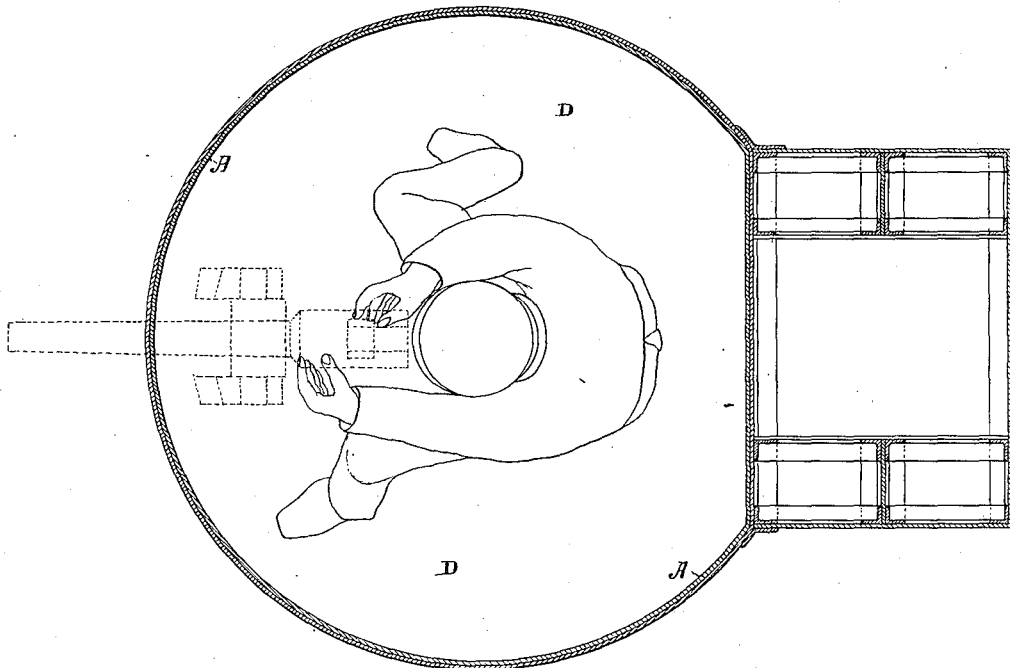
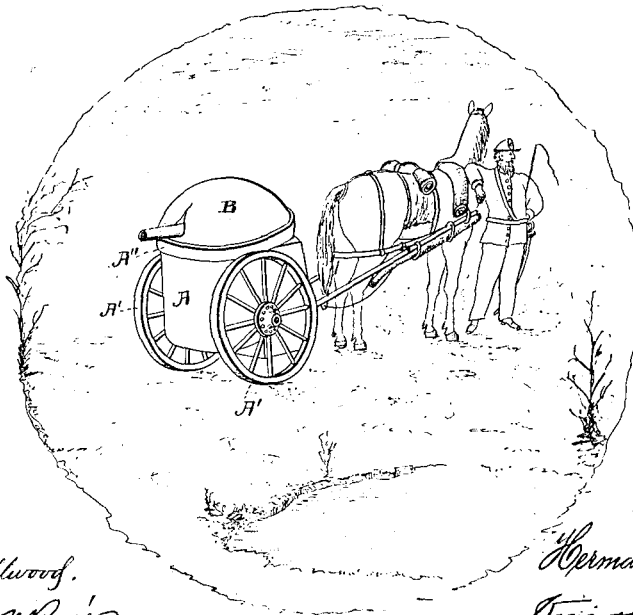

FIG. IV.



Attest.
Geo. T. Smallwood.
F. A. Spruill

Inventor:

Hermann Gruson.

By Knights attys.

(No Model.)

3 Sheets—Sheet 3.

H. GRUSON.
GUN CARRIAGE.

No. 367,617.

Patented Aug. 2, 1887.

FIG. V.

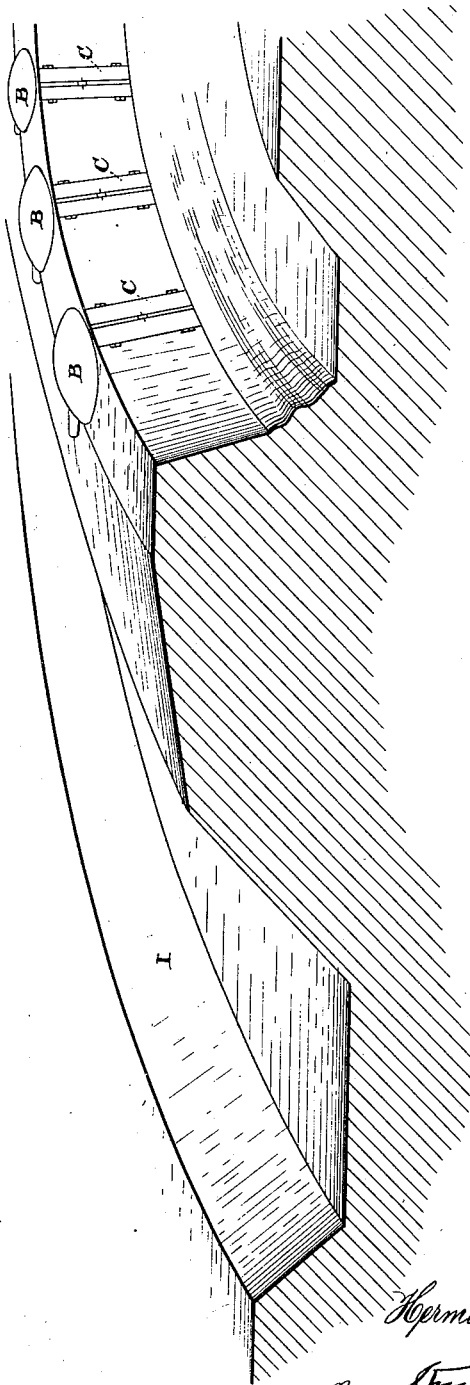

Attest,
Geo. T. Smallwood.
F. A. Hopkins.

Inventor:
Hermann Gruson.
By *[Signature]*
attys

UNITED STATES PATENT OFFICE.

HERMANN GRUSON, OF BUCKAU, NEAR MAGDEBURG, PRUSSIA, GERMANY.

GUN-CARRIAGE.

SPECIFICATION forming part of Letters Patent No. 367,617, dated August 2, 1887.

Application filed January 13, 1887. Serial No. 224,272. (No model.) Patented in Germany November 12, 1885, No. 35,955; in France December 1, 1885, No. 172,633; in Belgium December 3, 1885, No. 71,082; in Italy June 30, 1886, XX, 20,057, and XL, 49, and in Austria-Hungary September 30, 1886, No. 22,265 and No. 50,366.

To all whom it may concern:

Be it known that I, HERMANN GRUSON, a subject of the King of Prussia, and a resident of Buckau, near Magdeburg, in the Kingdom of Prussia, German Empire, have invented certain new and useful Improvements in Gun-Carriages, (for which I have obtained patents in the following countries, to wit: Germany, No. 35,955, dated November 12, 1885; France, No. 172,633, dated December 1, 1885; Belgium, No. 71,082, dated December 3, 1885; Italy, XX, 20,057, and XL, 49, dated June 30, 1886; Austria-Hungary, No. 22,265 and 50,366, dated September 30, 1886,) of which the following is a specification.

This invention relates to transportable gun-carriages, and is designed to provide for shielding or protecting the gunner against an enemy's fire, and at the same time enabling him to readily work the gun.

My improved gun-carriage is very advantageous for use in the construction of temporary fortifications or intrenchments, as hereinafter set forth.

In the accompanying drawings, Figure I is a vertical central section of the improved gun-carriage. Fig. II is a rear elevation partly in vertical section. Fig. III is a horizontal section of the shield or casing, showing the gun in dotted lines. Fig. IV is a perspective view illustrating the manner of transporting the gun-carriage. Fig. V is a perspective view illustrating the manner of utilizing the gun-carriage in the construction of temporary fortifications or intrenchments.

Like letters indicate corresponding parts throughout the drawings.

A is a metal casing, which is preferably of cylindrical form, as shown. This casing is mounted upon two wheels, A', the axles of which are secured to the said casing.

B is a cover or shield consisting of an armor-plate of steel or iron, and preferably of concavo-convex form, as shown. This cover or shield is supported by rollers *b* upon a circular rail, *a*, or it may be supported by any other suitable means, so that it can be readily turned upon or about its axis. The rail *a* is firmly secured to the casing A. The said casing is partly armor-plated, as shown at A², and is

provided with a door, C, through which the gunner can enter the said casing. It is, moreover, provided with a floor or platform, D. The cover or shield B closes the upper end of the casing A, and is formed with an embrasure or aperture, B', through which the barrel of the gun projects. The bearings E for the trunnions of the gun are firmly connected with the armor-plate top or cover B, which, consequently, takes up the recoil.

The elevation or depression of the gun is effected by the aid of a worm, *c*, gearing with a toothed segment, *d*, formed on one arm of a bell-crank lever, *d'*, which is pivoted upon studs or gudgeons *d''*, carried in bearings or brackets rigidly attached to the armor-plate top or cover B.

The gun is provided with trunnions *d*, whereby it is supported by the other arm of the bell-crank lever *d'*.

It will be observed that the gun's trunnions are considerably in rear of its center of gravity, and for the purpose of maintaining it in any desired position, I place beneath it, at a point near its center of gravity, a roller, *h*, of india-rubber, upon which it turns or fulcrums when its breech end is elevated or depressed, the rubber serving also to diminish the shock or jar. Ordinarily the gun's trunnions are forward of its center of gravity and serve as the fulcrums, upon which it oscillates when the breech end is elevated or depressed by suitable mechanism, the trunnions themselves remaining stationary. According to my invention, the gun fulcrums upon the roller *h*, the sighting being effected by elevating and lowering the trunnions. The worm *c*, is operated by means of a hand-wheel, *e*. The lateral adjustment or traversing of the gun is effected by turning the armor-plate top or cover B upon or about its axis. For this purpose rods or bars F G are connected with the said cover and with a seat, H, for the gunner. The gunner turns the said armor-plate top or cover by pressing his feet against the floor or platform D and his shoulder against the rod or bar G while sitting upon the said seat. Consequently, he does not require to use his hands for traversing the gun. He can therefore work the gun with great rapidity, as he can simultaneously

elevate or depress and traverse the same. Moreover, while working the gun, he is adequately protected against an enemy's fire by the casing A and cover or shield B.

5 If great precision is required in the aiming of the gun, I provide means whereby the worm *c* can be moved out of gear with the worm-wheel *d*, and a pinion, *f*, on the shaft *e* of the said worm brought into gear with a rack, *g*,
10 on the cover or shield B, so that the more accurate adjustment of the gun can be effected by turning the hand-wheel *e*.

Suitable shafts or posts are attached to my gun-carriages to facilitate their transport by
15 horse or other animal power.

In the construction of temporary fortifications or intrenchments, my armor-plated gun-carriages are used as follows—that is to say,
20 assuming that a large number of the said armor-plated gun-carriages are at disposal, they are transported to the place where they are to be used, and are arranged at suitable distances apart, as shown in Fig. V. A breast-work, I, of earth is then thrown up, which in-
25 closes or surrounds the casings of the said carriages with the exception of the doors thereof, and leaves the covers or shields of the carriages free to be turned as required. In this manner it is possible, in the time which would
30 be required for making a skirmishing-trench, to erect a battery of my armor-plated gun-carriages, and when the position appears no longer tenable, the battery can be very readily dismantled and the guns and carriages re-
35 moved.

If the fortification or intrenchment is to be of a more permanent character, the earth-work can be further strengthened by masonry or other means, while inversely, in cases where
40 only infantry-fire is to be withstood, the casing does not require protection, as it can be made of sheet metal sufficiently strong for the purpose.

It is evident from the foregoing description
45 that one man can work the gun. For supplying the ammunition another man is required, who sits at the entrance of the casing and puts the cartridges in boxes, which he suspends from a rail, K, secured to the casing A, so that
50 the cartridges are always easy of access for the gunner, the said boxes being provided with rollers which run upon the said rail.

I am aware that it has been proposed to support the concavo-convex roof of an armor-turret by means of a central column upon which
55 it is capable of revolving; but this is not the equivalent of so constructing the roof and the side walls of the casing that the former will bear at its edges upon the upper edge of the
60 latter so as to be capable of revolving. The latter construction is far preferable, not only because less expensive, less complicated, and consequently less liable to be rendered inoperative by shock or recoil, but also because it af-
65 fords much more room on the interior of the turret for the gunner, which is quite a desideratum in guns of the class to which the pres-

ent invention relates—*i. e.*, portable field-guns.

I am also aware that the side walls of armor-turrets have been supported by anti-friction rollers, which enable its rotation; but such is not the equivalent of my present invention.

I claim—

1. The combination of a shield or casing, a revoluble cap or cover supported at its edges by said shield, and a gun carried by said cap or cover, substantially as set forth. 75

2. The combination of a shield or casing, a concavo-convex cap or cover supported at its edges by said shield or casing, and a gun carried by said cap or cover, substantially as set forth.

3. The combination, with a shield or casing, 85 of a revoluble armor resting upon said shield or casing, a gun carried by said armor, a seat also carried by said armor, and a fixed platform or floor located at such distance from the seat as to be conveniently reached by the gun- 90 ner's feet, substantially as set forth.

4. The combination, with a shield and a bearing-ring supported thereby, of a revoluble cap or cover, rollers interposed between the edge of said cap and the bearing ring, and 95 the gun carried by said cap, substantially as set forth.

5. The combination, with the metal shield or casing, the revoluble cap or cover, and the gun carried thereby, of the seat for the gunner 100 suspended from said cap or cover, substantially as set forth.

6. The combination, with the sheet-metal shield or casing A, the armor plate or ring A², 105 secured to the top thereof, the bearing-ring *a*, the superposed revoluble armor-plate B, resting upon the bearing-ring through the medium of rollers *b*, and the gun carried thereby, substantially as set forth.

7. The combination, with a revoluble support for the gun, of a circular track or way, and an ammunition-box having wheels resting upon said track, substantially as set forth. 110

8. The combination, with the shield or casing A, and the ground-wheels A', of a gun, and 115 a revoluble support surmounting said casing by which the gun is carried, substantially as set forth.

9. The combination of the brackets E, the bell-crank lever *d'*, fulcrumed therein, the 120 gun having trunnions bearing upon one arm of said lever, the segment *d*, formed on the other arm, and the worm engaging said segment, substantially as set forth.

10. The combination of the shield or casing 125 A, having the door C at one side thereof, the revoluble top, the gun carried by said top, and the ground-wheels A', supporting said shell or casing, substantially as set forth.

HERMANN GRUSON.

Witnesses:

JULIUS VON SCHÜTZ,
EMIL KALLNECKER.